

Enhanced methods optimize ownership costs for catalysts

Novel model-based innovation techniques enable simultaneous optimization of catalyst formulations and operating reactors

C. BÄUMLER, Süd-Chemie, Munich, Germany, Z. URBAN and M. MATZOPOULOS, Process Systems Enterprise Ltd., London, United Kingdom

Catalysts are ubiquitous throughout the hydrocarbon processing industries (HPI). Processing companies rely on catalyst systems to produce high-quality consumer products. Catalyst manufacturers invest heavily on research to optimize the catalysts' total cost of ownership (TCO).

Advanced process modeling (APM) methods are being applied to streamline the analysis of new catalysts while incorporating real-world data when designing innovative HPI catalysts. Applying such techniques allows suppliers of catalytic technologies to simultaneously optimize new catalyst development and supply complete "life cycle" services to customers.

To provide this service, a precise understanding of catalyst performance at a laboratory, pilot plant and commercial plant levels is required. This can be accomplished by using model-based techniques that capture fundamental knowledge of catalytic processes at all levels—from diffusion-free micro-scale reaction systems to macro-scale industrial unit levels—in a framework to provide quantified decision support. At the same time, this framework serves as a vehicle for advancing the understanding of the catalytic system by applying model-based data analysis techniques.

Using a classical approach during the development process, the various catalyst samples are first tested in the laboratory. Promising formulations are tested more extensively in pilot facilities, with the successful candidates going on to full-scale commercial implementation.

The difference is that the process involves modeling at every stage, using a formal set of techniques known as *model-based innovation*. Laboratory, pilot and commercial-scale operations are modeled using a consistent set of validated first-principles models implemented within a single framework.

The high-accuracy predictive models are used both as the primary tool for data analysis, and as a decision support framework for optimization of important process aspects. In addition, by successfully closing the loop from R&D to commercial plant operation, developers can continuously enhance new catalysts based on real-time operating data from operating reactors.

The modeling is done using a single tool throughout, with the same sub-models, such as the reaction set model used within different geometries and flowsheet arrangements at each stage. This approach simplifies collecting, analyzing, deploying and transferring data through the different scales of operation.

To minimize time and the cost of model building, the techniques use rigorous off-the-shelf models that include thermal and transport properties information and "starting point" estimates of kinetics. Validation is done so that the model parameter information (such as reaction kinetic constants) is valid at any scale of operation.

Application to process optimization. Once a fully validated model of a commercial reactor process is available, it can be used in conjunction with formal

mathematical optimization techniques to optimize many different aspects of operation. Typical uses of a model-based approach in support of catalyst recommendations are to:

- Rank catalyst alternatives and select the optimal catalyst type, i.e., which catalyst to use to favor the desired reaction under particular feedstock and operating conditions and throughput requirements based on its predicted performance in the reactor model
- Determine a catalyst loading regime, i.e., how to combine different grades of catalyst along the length of a fixed bed to achieve desired temperature profiles

- Determine optimal operating conditions for given plant constraints
- Reduce pilot plant testing.

For support of plant operation, models are used to:

- Recommend operating strategies to achieve the customers' targets with regard to maximizing specific catalyst productivity
- Support customers in achieving specific turn-around dates
- Determine optimum operating policies for changes in feedstock or other upsets or events
- Troubleshoot poor operation.

The high-quality information generated by such models can also be used for decision support throughout design and subsequent operation of reaction systems, as well as to fast-track process innovation. Three principal applications will be discussed here: optimization of a customer's operation for an existing commercial pro-

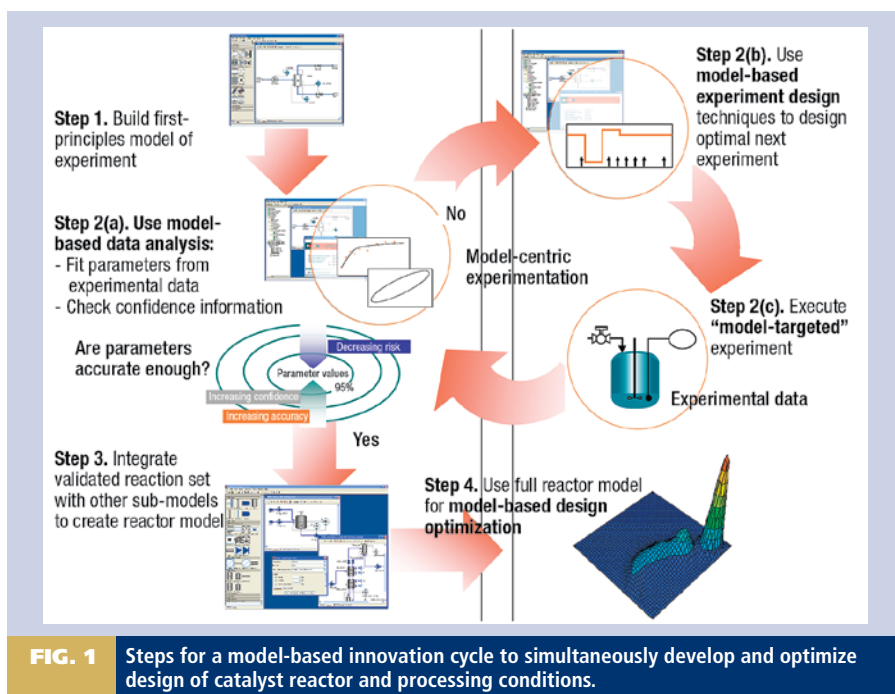

cess to meet a specific turnaround date, the optimization of a temperature profile along the reactor by modifying the catalyst loading, and enhancements to the catalyst's characteristics based on field experience.

APM and model-based innovation. The key technology applied is APM. Advanced process models have two attributes that make them capable of a significantly higher degree of predictive accuracy than "black-box" simulation models.

The first is a detailed *first-principles representation* of all relationships that define the process, from the micro-scale diffusion of molecules between bulk fluid and catalyst, and within the catalyst pores, to the macro-scale circulation of cooling fluid in the reactor shell. This is constructed within a modeling framework, by describing the physics, chemistry and chemical engineering relationships in terms of heat and material flow, reaction, diffusion and geometry equations, plus the interaction between process flowsheet units. Most relationships, including the detailed multicomponent mass and heat transfer, are well known and documented. All the fundamental models used in the cases described here were taken from an existing library.

The second ingredient is *accurate model parameter* information derived from real-world—laboratory, pilot or operating—data, using mathematical optimization-based parameter estimation techniques in a process known as model validation. Combining these factors provides models with a highly accurate predictive capability over a wide range of operating

conditions. For example, if validated properly, reaction kinetic parameters determined from small-scale laboratory experiments on catalyst pellets will be valid over the full operating range of the commercial unit.

Once a fully validated model is available, it is possible to apply formal mathematical optimization techniques to optimize many different process design and operation variables, including time-invariant quantities (reactor diameter), time-dependent variables (startup set-point trajectories) and integer (discrete) quantities (such as number of units in parallel or series).

When the data doesn't fit: model-targeted experimentation. The more accurate a model, the more accurate the information it generates; thus, lowering the margin of error (and the risk) associated with the results. Higher accuracy modeling translates into increased profitability and—more important—better-managed risk at all stages. In addition, an accurate predictive model provides the means for rapid response to changing market conditions. However, the accuracy of the model parameters depends heavily on the quantity and quality of information—not just the number of data points—within the experimental data.

As described earlier, experimental data can be used to improve models. Less well-known is that models can be used to improve the quality of experimentation—and hence the information content of experimental data—with great effect. This is achieved through *model-targeted experimentation*, an

activity aimed at generating the maximum accuracy of *model parameters* with the minimum number of experiments. This differs from traditional approaches, where experimentation is aimed at optimizing a specific aspect of design or operation. The intention is that once the model parameters have been established accurately, many different aspects of design and operation can be optimized.

Model-based innovation: Stepwise approach to optimizing design and operations. Model-based innovation is the collective term applied to a set of methodologies aimed at the application of fully validated advanced process models to the optimization of design and operations.

The steps to achieving a fully validated model (Fig. 1) are:

Step 1. Construct first-principles models of the fundamental phenomena being studied. This involves creating first-principles models (initially) of the system for which experimental data are to be fitted, rather than for the target equipment. For example, if reaction kinetic constants are to be determined using information from a single catalyst-packed tube in a pilot plant, the model constructed will comprise sub-models of:

- Reaction set, including all reaction rates
- Heat and mass transfer relationships, including, where appropriate, diffusion of reactants and products to and from the catalyst particle
- Catalyst (geometry, active site information, pore information)
- Catalyst-bed characteristics (pressure drop, bed and tube-wall heat transfer characteristics), if applicable, within the equipment geometry
- Thermodynamics and physical properties.

Ideally, the model is constructed in a modular form that allows the components to be separated so they can easily be utilized within other geometries. Such models are available in library form and can be customized to meet particular requirements rather than be constructed from scratch.

Step 2(a). Apply model-based data analysis to estimate parameters. The parameter estimation techniques used in APM techniques make it possible to use models themselves to extract high-accuracy parameter information from experimental data. It is possible to estimate simultaneously large numbers of parameters occurring in complex nonlinear mathematical models using measurements from any number of dynamic and/or steady-state experiments.

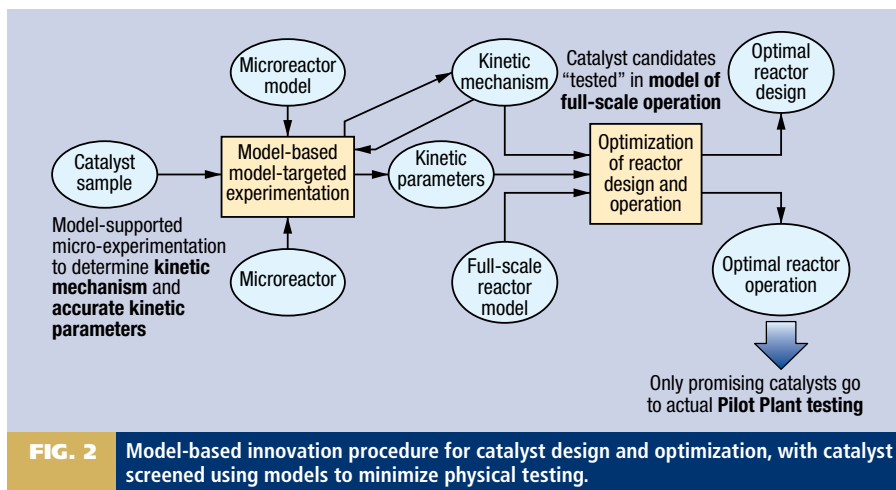

FIG. 2 Model-based innovation procedure for catalyst design and optimization, with catalyst screened using models to minimize physical testing.

Maximum likelihood techniques allow the errors inherent in practical experimentation to be taken directly into account, or to be estimated simultaneously with the model parameter values.

In addition to parameter values, this process also yields estimates of the accuracy of these values in the form of confidence intervals. Modern risk analysis techniques can translate this information into an assessment of the risk involved in using these parameter values for subsequent design and operational decisions. While presented here as a step in the creation of a validated model, model-based data analysis has great benefit in its own right. All experimental data ultimately needs to be analyzed and used to adjust key design parameters such as reaction kinetic coefficients or heat transfer coefficients. It is possible to introduce a new level of accuracy into data analysis by using rigorous first-principles models rather than statistical methods.

Step 3. Build the full model. Once the parameter confidence analysis indicates an acceptable margin of error in the parameters, the sub-models can then be used to build the full equipment model. If necessary, this can be validated against operating or test-run data to determine overall heat transfer or flow coefficients. It should not be necessary to estimate parameters already fixed from the earlier laboratory or pilot validation at this stage.

Step 4. Execute and optimize. Once the full validated model of the process is available, it is ready to be used for a variety of design and operational activities, as described above.

Refining parameter: Model-centric experimentation. Frequently, the confidence intervals from the model-based

data analysis in Step 2(a) indicates that the parameters calculated from the initial experimental data are not within acceptable risk limits, and further experimentation is required. Rather than being aimed at providing, for example, sets of concentration data at certain temperatures, these experiments are aimed solely at generating information that increases the accuracy of model parameters to an acceptable level. The process is known as model-centric experimentation, and it adds two further steps:

Step 2(b). Model-based experiment design. A major development in the last few years has been the emergence of model-based techniques for the design of experiments. In contrast to the usual statistically based techniques (e.g., factorial design), model-based experiment design takes advantage of the information that is already available—in the form of the mathematical model—to design experiments that yield the maximum amount of information, thereby minimizing the uncertainty in any parameters estimated from the results of these experiments. This optimization-based technique is applicable to the design of both steady-state and dynamic experiments. It can use any experiments that have been already performed as a starting point.

Typical decision variables determined by this technique include the optimal conditions under which the new experiment is to be conducted (e.g., the temperature profile to be followed over the duration of the experiment), the optimal initial conditions (e.g., initial charges and temperature) and the optimal times at which measurements should be taken (e.g., sampling times for offline analysis).

The total effect is that the required accuracy in the estimated parameter values may be achieved using the minimum number of experiments.

Step 2(c). Model-targeted experimentation. The model-targeted experiments are carried out, following the experiment procedure determined (Fig. 1) from the model-based experiment design in Step 2(b). Following the experiment, model-based data analysis is applied to determine the parameter values and their accuracy. Steps 2(b), 2(c) and 2(a) are repeated until a satisfactory level of parameter confidence is obtained.

Using model-based techniques.

The model-based procedures within a classical reaction engineering framework were used to build two models:

- High-fidelity model of a methanol synthesis loop
- Detailed model of a common partial oxidation process.

The procedure is shown schematically in Fig. 2. In both cases, first, laboratory experimentation was done on small catalyst samples to determine the reaction kinetic parameters and catalyst characteristics while simultaneously using the generated information to refine the respective sub-models.

Subsequently, the catalyst underwent pilot plant testing to determine the heat and mass transfer influence on the reactor performance, by calculating parameters such as bed heat transfer coefficient. Once sufficient confidence was established in the sub-models, these were integrated into models for commercial systems.

Laboratory testing and analysis.

First, the catalysts were tested in a classical Berty reactor at close to isothermal conditions. The primary objective of this testing was to determine the reaction kinetic parameters (activation energies, pre-exponential coefficients as well as adsorption and desorption factors) for the catalytic reactions to a suitable level of confidence. Secondary objectives were to determine the statistically most suitable kinetic model for the given process.

A model of the laboratory reactor system (Fig. 3) was built, containing sub-models—for example, a model of all rate equations and catalyst characteristics. These sub-models were built in such a way that they could easily be transferred to models of different scale equipment including the pilot-scale and commercial reactors.

Experiments were executed covering a wide range of conditions to provide sufficient data for calculation of the kinetic constants. Once the data were collected, the model of the Berty reactor was used for the parameter estimation of the kinetic

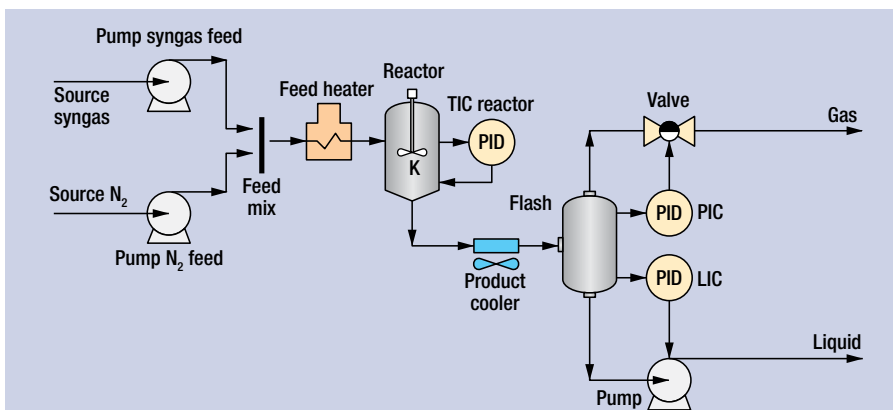

FIG. 3 Typical Berty reactor flowsheet used to validate reaction kinetic parameters.

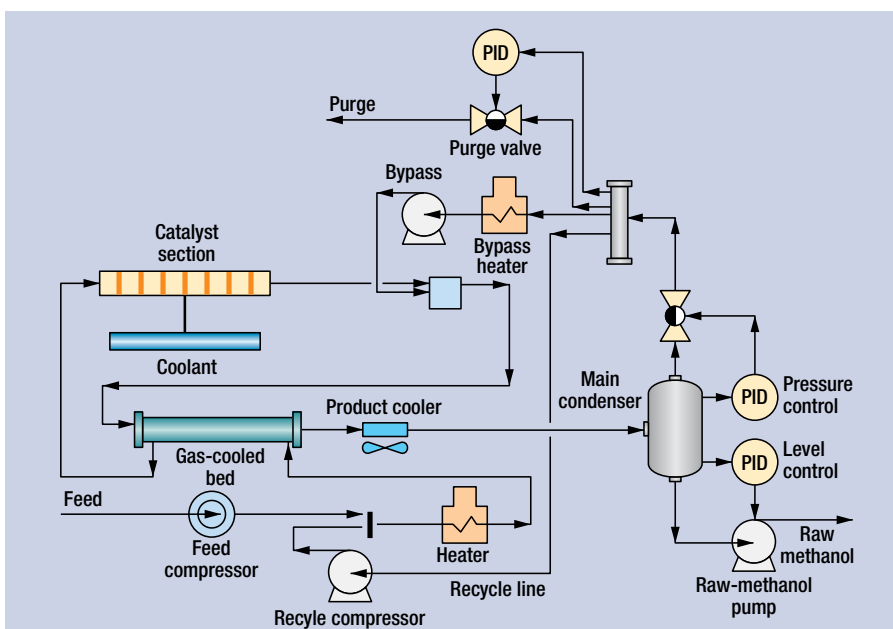

FIG. 4 Typical simulation flow sheet for a methanol synthesis loop.

constants. Instrument errors were also calculated during the parameter fit, providing useful quality assurance information.

The parameter estimation generated confidence (essentially, “accuracy of fit”) information that could be used to determine whether further experimentation was required to improve accuracy, and if necessary, design the optimal experiments. The confidence information was also used for model discrimination, to improve the reaction set from the original. For example, poor confidence intervals imply that the reaction system described in the model could not have produced the observed data, and that additional or different reactions have to be considered. The ability to construct an accurate validated reaction set is a key

benefit of the combination of experimental data and first principles modeling described here.

Pilot-plant testing. Single-tube pilot plant testing was carried out. This involved packing a tube with the target catalyst, then measuring flows and compositions under carefully controlled conditions. In both cases, the test data were used to fit bed parameters, such as bed and wall heat transfer coefficients.

The two-dimensional single-tube model was constructed using library models. These contain first-principles models of the fundamental chemical phenomena including diffusion of reactants and products between bulk fluid and catalyst and intra-particle diffusion. They also contain

accurate relationships for internal bed heat transfer and bed-to-wall heat transfer.

Commercial plant. In both cases, the commercial plant involved a fixed catalyst bed in a multitubular configuration. The beds—inside tubes in one case and outside in the other—were modeled using library models as a two-dimensional (axial and radial) distributed system in order to take into account variations of temperature and concentration at different points. A third distribution is often added for a porous catalyst, to model reactant and product movement within the pores, but was not used in this case.

Application cases. In the first case, information generated by the detailed model was used to advise a customer on the optimal operating strategy to maximize production within a given remaining catalyst lifetime scenario while maintaining product quality specification. The second case determined an optimal catalyst combination for maximizing catalyst life on a given commonly applied tubular reactor technology taking the physical unit constraints into consideration.

Case 1: Maximizing production.

Fixed-bed catalytic reactors are widely used throughout the chemical and petrochemical industries in the form of multitubular reactors. Initially, the reactor is charged with catalyst of a high activity and selectivity. The catalyst promotes a high reaction rate for the desired reaction and ensures that the desired reactions are preferred over other reactions that may occur. Over time, as catalyst sites are poisoned or become inactive for any other reason, catalyst activity and selectivity declines. Depending on the specific deactivation mechanism, the form of the deactivation curve could be anywhere between linear and exponential.

To maintain throughput and product quality, this is counteracted by increasing the operating temperature or by adjusting other operating variables. Increased temperatures increase the risk of hot-spot formation and subsequent catalyst burnout, thus creating inert areas within the bed. In some cases, a hot spot could create a reactor runaway situation leading to potentially serious damage of reactor equipment.

Since the number of variables that can be used to counteract catalyst deactivation in a commercial plant is limited, an optimized operating strategy must be developed to match the specific production targets of

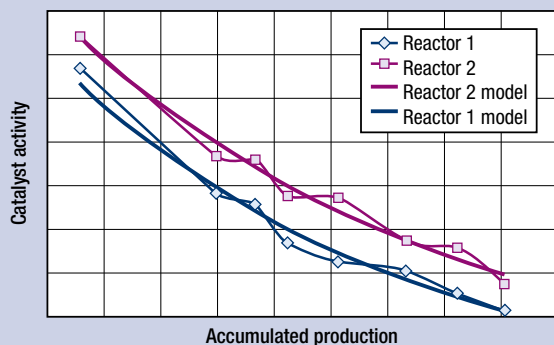

FIG. 5 Catalyst activity curves—the theoretical curve and current plant operating data.

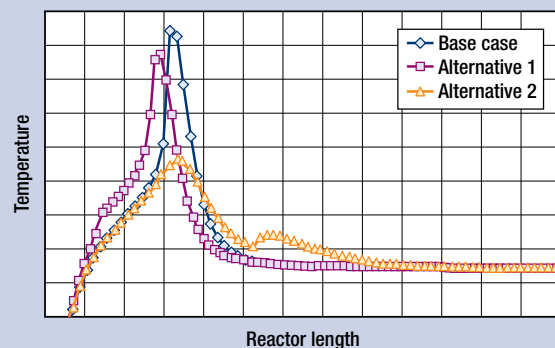

FIG. 6 The tube center temperatures for three catalyst loadings show how it is possible to significantly reduce maximum temperatures while maintaining desired production yields.

the customer. This poses an economic optimization problem. Due to the number of variables involved, it can only realistically be solved if the process model contains sufficient detail and the modeling framework has the solution power to handle the resulting large set of implicit equations.

In many cases, other factors determine shutdown times. This was the situation in Case 1, where the operating company wanted to maximize production from a methanol synthesis loop (Fig. 4) for a remaining operation period of six months to provide a better fit with other maintenance schedules.

“Making life easier” for companies operating reactors using a vendor’s catalysts involves providing accurate estimates of the remaining catalyst lifetime at any point. The catalyst supplier achieves this by constructing and maintaining accurate activity curves showing the activity of a catalyst at any point during its service life.

The activity curve is an evolving entity, regularly augmented by operating data from the commercial plant. Data is processed through the rigorous model-based estimation procedures to generate an up-to-date curve that represents the catalyst activity accurately at that time, given plant measurements over the preceding period (Fig. 5). Because the plant model has been validated in all key respects using a formal methodology, performance variations seen in the plant operating data can only be caused by changes in the catalyst.

Once current activity has been determined, there are a number of degrees of freedom that can be used as optimization variables in the coupled reactor process: feed temperature, cooling medium temperatures, recycle proportion, etc. The model was used to determine the optimal settings for these variables in order to achieve the required production for the consideration period.

A major additional benefit from this approach is that the feedback from operating data and the analysis of spent catalyst allows manufacturers to fine-tune key catalyst properties such as poison resistance, surface area stabilization, pore volume, specific surface area and many more, using a rigorous analytical framework.

Case 2: Optimal catalyst combination. While Case 1 deals with an existing operation, Case 2 involves the design of a packed bed for a new reactor using a commonly occurring partial oxidation reaction. Applying the model-based approach, it is possible to design an “ideal bed” using different grades of catalyst and inert along the length of the bed (i.e., different catalyst loading regimes), while considering physical unit constraints such as geometry and heat transfer.

Fig. 6 shows the significant impact of selecting the right catalyst activity on the total temperature profile along a reactor tube. For all three cases, the total conversion was kept constant. By optimizing the catalyst packing configuration, it is possible to determine a configuration that maintains low temperatures at points in the bed usually subject to significant deactivation, while maintaining the required throughput. This minimizes loss of activity at key points in the bed, or at least delays it for as long as possible. In addition, the bed can be packed in such a way that, if and when loss of activity occurs, the catalyst packing allows downstream sections to take over key reactions so that throughput is maintained for as long as possible. Applying rigorous models to simulate alternative catalyst loadings minimizes the effort for expensive and time-consuming pilot testing.

Typically, multiple-tube section models are used to represent the different sections of catalyst and inerts along the length of a

single tube. The effect of different catalyst profiles can be studied simply by varying the dimensions of the tube section models and the characteristics of the catalyst within them. This activity requires fundamental knowledge of the various catalyst types from micro pilot-plant testing. Once an optimum catalyst loading is found for a given set of operating conditions, confirmation of the results is done via a special test program in the pilot plant unit. This consists of a commercial reactor tube capable of operations under industrial conditions. Because of the trade-off between bed temperature and throughput at any point in the catalyst cycle, once again this is an optimization problem that requires detailed validated models and a comprehensive optimization framework. **HP**

Christoph Bäumler is director engineering services EMEA in the business unit catalytic technologies at Süd-Chemie AG, Munich. He has more than 20 years of experience in various fields of industrial catalysis including R&D, technical service, reactor & process simulation. He holds an MS degree in chemical engineering from the University Erlangen Nürnberg, Germany and specializes in the development and application of advanced catalytic reactor simulation tools.

Mark Matzopoulos is a director of Process Systems Enterprise Ltd. He has 25 years experience in the development and application of process simulation and modeling tools in steady-state and dynamic simulation, operator training, control system checkout and plant optimization. He writes extensively about the application of advanced process modeling. He has a chemical engineering degree from the University of Cape Town, South Africa. He is a finalist in the Royal Academy of Engineering MacRobert Award 2007.

Zbigniew Urban is a principal consultant in Process Systems Enterprise Ltd. He is responsible for advanced process modeling applications and PSE’s R&D program for development of novel modeling technology. He holds an MS degree in chemical engineering from the Warsaw University of Technology, and specializes in reaction engineering, mass transfer modeling and modeling of particulate systems.